



THERMAL BRIDGING SOLUTIONS FOR COMMERCIAL BUILDINGS

A more accurate way to identify and prevent heat losses due to thermal bridging

THERMAL BRIDGING THROUGH STEEL AND CONCRETE STRUCTURES CAN HAVE A SIGNIFICANT IMPACT ON A BUILDING’S ENERGY PERFORMANCE.

Thermal bridging through steel and concrete structures can have a significant impact on a building’s energy performance. Reducing heat flow through a building’s thermal envelope reduces energy consumption as well as potential condensation issues. Thermal bridging has been recognized as a significant factor in building envelope heat loss. As early as 2006, many European countries had already instituted improved energy rating systems for new buildings to better control and reduce domestic energy consumption. Nearly 10 years ago, in response to an EU initiative to improve the energy performance of buildings even further, Armadillo Ltd. developed its first thermal break material, “Armatherm” to prevent heat loss due to thermal bridging.

Since 2011, drawing on Armadillo Ltd. ’s experience, Armatherm has been working with architects and structural engineers in North America to improve building design details and reduce heat loss due to thermal bridging within the building thermal envelope.

Armatherm™ thermal break materials provide a combination of low thermal conductivity and high compressive strength and have been designed and tested to prevent thermal bridging. Armatherm™ has been proven through three dimensional modeling to reduce heat loss in wall assemblies, transitions and structural connections throughout the building envelope.

Armatherm™ solutions can be used anywhere a penetration or transition exists in the building envelope creating a thermal bridge. Solutions to minimize heat loss include balcony, canopy, parapet, masonry shelf angle, cladding/Z-girt connections and wall-to-foundation transitions. Improvements in the effective U value of wall assemblies can be as much as 70%.

We are a collaborative, design-build partner who can assist in determining the extent of thermal bridging heat loss on building envelope performance including thermal modeling and connection design calculations. We look forward to working with you.

CONTENTS

4

THERMAL BRIDGING AND THE BUILDING ENVELOPE

- 5 THERMAL CONDUCTIVITY
- 6 LEED POINTS & ENERGY EFFICIENT BUILDINGS
- 7 CALCULATING HEAT LOSS THROUGH THERMAL BRIDGING
- 8 THERMAL TRANSMITTANCE
- 9 CALCULATING HEAT FLOW
- 10 THE IMPACT OF THERMAL BRIDGING
- 11 A WORD ABOUT CONDENSATION

12

STRATEGIES TO PREVENT THERMAL BRIDGING

- 13 REDUCING THERMAL TRANSMITTANCE
- 14 OUR PRODUCTS
- 24 ADDITIONAL ENVELOPE LOCATIONS
- 26 TERMS

THERMAL BRIDGING & THE BUILDING ENVELOPE

Conductive heat transfer through the building thermal envelope creates significant energy losses. Think canopies, balconies and cladding attachments.

- Thermal bridging can reduce the R value of a wall assembly by as much as 50%
- Thermal bridging can be responsible for up to 30% of a dwelling's heat loss

WHAT ARE THERMAL BRIDGES?

To achieve higher R and U values, thermal bridging and air leakage must be minimised to reduce building energy consumption. Thermal bridges are highly conductive structural elements that create heat transfer between the exterior and interior of the building thermal envelope. Heat moves from warm to cold and is transferred via conduction, convection or radiation. All building materials conduct heat and each has a thermal conductivity value (k). The U-Value, also known as thermal transmittance, is the rate of transfer of heat through a structure divided by the difference in temperature across that structure. The units of measurement are W/m²K. The R value or thermal resistance to heat flow of a material is equal to the material thickness divided by its k value. Thermal bridging occurs through any material that is more conductive than the insulation it bridges.

Thermal image showing areas in a building envelope where thermal bridging is creating heat losses.

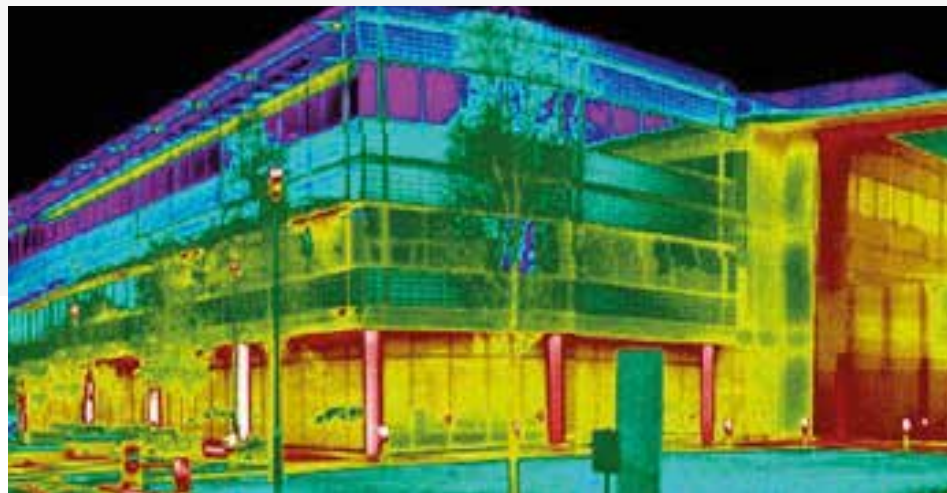

(Source: www.inspectionfacades.com)

THERMAL BRIDGING

THERMAL CONDUCTIVITY

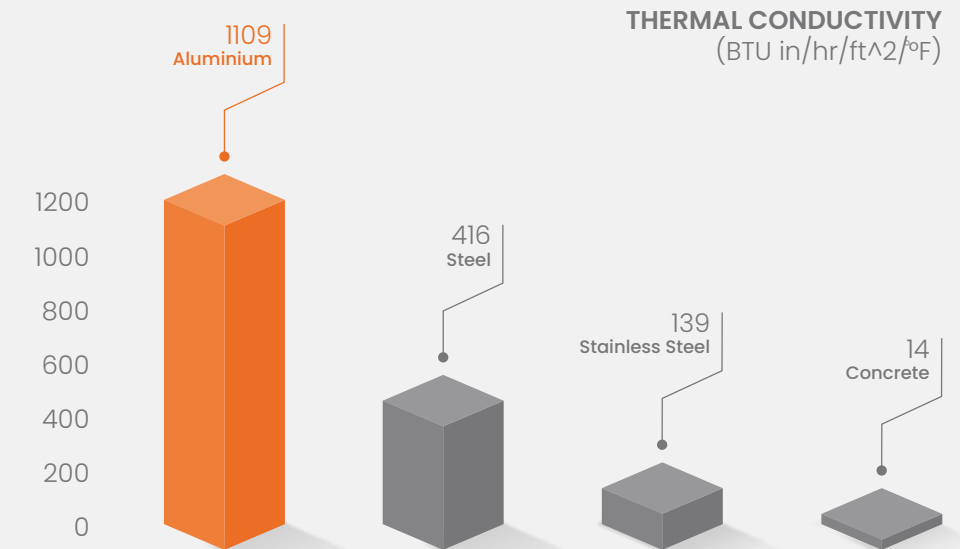

It has been estimated that the total heat flow through typical wall assemblies is underestimated by as much as 20%–70% due to thermal bridging. Simply adding insulation to walls has been proven to not necessarily decrease the energy use of a building. Heat flow paths (thermal bridges) allow heat to by-pass the insulation, negating any benefit of having more insulation in the wall. By ignoring thermal bridging, the unaccounted for heat flow creates higher heating and cooling costs, oversizing of the HVAC equipment, operational inefficiencies and higher energy consumption.

Currently, ASHRAE fundamentals provide a simple equation to determine the U-value of a wall system based on parallel heat paths and weighted averages based on area. The U factor tables in ASHRAE 90.1 are not in many instances representative of actual assembly performance because they do not include an allowance for heat flow through major thermal bridges.

LEED POINTS & ENERGY EFFICIENT BUILDINGS

The ASHRAE 90.1 standard provides minimum requirements for energy efficient designs for commercial buildings.

There are two paths for building designers to use to comply with 90.1. Using the prescriptive path, all components of the building meet the minimum standards specified by the sections within ASHRAE 90.1. Using the performance path, a proposed building design is demonstrated (through building energy simulation) to use less energy than a baseline building built to ASHRAE 90.1 standards. The performance approach is also used to demonstrate design energy efficiency and the resultant percentage improvements over ASHRAE 90.1 are used for awarding energy points within the LEED rating system.

Within LEED, Energy and Atmosphere (EA) credits in the form of points are given for buildings that demonstrate improvements in energy consumption. Attainment of energy consumption objectives can be met by reducing or eliminating thermal bridging in the envelope design, helping to improve the overall performance of the building envelope.

The goal of updated energy conservation codes for building design, which now mandate acceptable thermal envelope performance based on geographic region, is to reduce the amount of energy needed to condition the occupied space.

Minimum R values required to meet code by geographic region are given in ASHRAE 90.1 (2013) for the prescriptive path method. Minimum effective R value requirements are given in the Canadian National Energy Code for Buildings, NECB (2011).



CALCULATIONS

CALCULATING HEAT LOSS THROUGH THERMAL BRIDGING

In order to change current practice for dealing with thermal bridging, communication among all members of the design team is essential. Increasing the U value of wall assemblies affects several aspects of building design. Today, new thermal performance methods can be used and integrated in collaboration by all parties on the design team. Identifying inefficient details for example, will help in calculating more accurate heating and cooling loads, reducing cost and energy consumption and improving the performance of the building envelope.

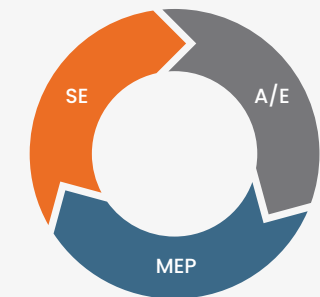

MINIMIZING BUILDING ENERGY LOSS TOGETHER

In the past, the effects of thermal bridging were difficult to define. In addition to the heat flow normally transmitted through the building envelope (air leakage for example) multi directional heat flows are created at thermal bridge locations. Therefore, the use of effective R and U values rather than nominal values is a more accurate measure of thermal performance. How do we more accurately calculate the heat loss contribution of a thermal bridge?

To determine the thermal performance of a building envelope that includes thermal bridging, the envelope components need to be treated as clear field assemblies and interface details (thermal bridging anomalies). Clear field assemblies are wall, roof or floor assemblies which include the effects of uniformly distributed thermal bridging components such as; brick ties, cladding attachments or framing studs. Interface details are those that interrupt the uniformity of the clear field, for example; parapets, intersections, roof penetrations or balcony/canopy connections. The thermal transmittance (U value) of clear field and interface details can be determined most accurately through thermal modeling.

THERMAL TRANSMITTANCE

Area weighted calculations are commonly used to calculate R and U values of wall assemblies. Typically this is done by weighting the heat flow through the materials by the area they take up.

Using the physical area of a thermal bridge assumes the heat flow paths through a detail are one dimensional and parallel. However, highly conductive building materials create lateral or multidirectional heat flows to other components that are not accounted for in parallel heat flow assumptions.

Parallel heat flow path assumptions and area weighting do not accurately define the effects of a thermal bridge. How do you calculate the area of a thermal bridge in three dimensions?

Using linear and point transmittances simplifies things by ignoring the area of thermal bridges. The heat flow through a wall assembly is compared with and without the thermal bridge detail and the difference in heat flow is related to the thermal bridge bypassing the thermal insulation. The additional heat flow created by the bridge is not dependent on area, rather it is characterized by linear length or a single point within the wall assembly.

Example of linear transmittance (heat flow) at building intersections.

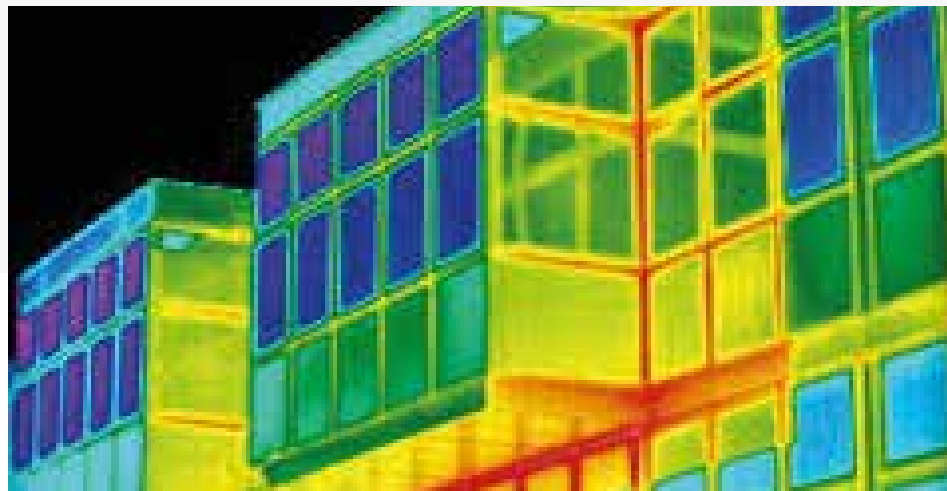

(Source: www.centraltexasthermalimaging.com)

CALCULATIONS

CALCULATING HEAT FLOW



CLEAR FIELD

U_o

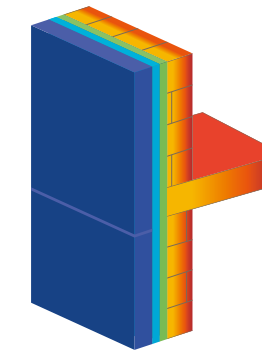

LINEAR

Ψ
psi

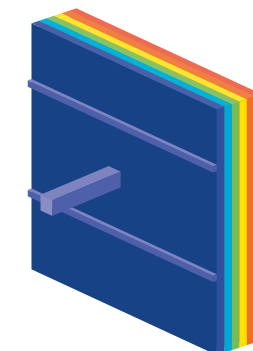

POINT

χ
chi

Examples of thermal transmittance and heat flow through the building envelope. Steel girts can be seen in the clear field wall assembly, a steel shelf angle bolted to a slab edge as an example of a linear detail and a single beam penetrating the envelope as a point detail. (Source: Morrison Hershfield)

Linear and point transmittances along with clear field transmittances can be used to determine the overall heat flow for any size wall or roof by calculating effective R and U values that include the effects of thermal bridging. For whole building load calculations, the linear and point transmittances are simply added to the clear field U value of a given assembly area to calculate the overall thermal transmittance.

The overall heat flow can be found by adding all of the components together as shown below.

$$Q = \sum Q \text{ thermal bridges} + Q_o = \sum (\Psi * L) + \sum (\chi) + Q_o$$

Or, as heat flow per area:

$$U = \frac{\sum (\Psi * L) + \sum (\chi)}{A} + U_o$$

Where A, is the total opaque wall area.

WHAT IS THE IMPACT OF THERMAL BRIDGING ON OVERALL BUILDING PERFORMANCE?

Using the methodology described here, allows details to be characterized by the amount of extra heat flow they add to a wall assembly. The additional heat flow due to thermal bridging is now included in the calculation of the U value of an assembly and thermal break solutions can be evaluated to improve heat loss. By characterizing the heat flow in details in this manner, the design team can more accurately make decisions as they relate to the energy efficiency of their building design.

Thermal transmittance values are more accurately found by simulation using three dimensional heat transfer software. The consulting firm, Morrison Hershfield has conducted extensive research evaluating hundreds of typical construction details, wall assemblies, intersections and transitions using the principles of thermal transmittance. They have demonstrated that two dimensional models cannot capture the actual heat flow path through three dimensional intersections and cannot accurately estimate thermal transmittance (U value) and surface temperatures that are of interest in preventing condensation.

EXAMPLE CALCULATION

Consider a wall assembly that is 10 feet high and 6 feet wide which has an effective clear field U value (U₀) of 0.051 BTU/hrft²oF (R₀ = 19.6). The wall has one interface detail due to a shelf angle where the linear transmittance (Ψ) is 0.314 BTU/hrftoF. The total heat loss of the wall assembly is given by:

$$Q = \sum (\Psi * L) + Q_0$$

$$= (0.314 * 6) + (0.051 * 60)$$

$$= (1.88) + (3.06)$$

$$= 4.94 \text{ BTU/oF}$$

$$U = \frac{Q}{A} \quad U_{\text{eff}} = 0.082$$

$$U = \frac{4.94}{60} \quad R_{\text{eff}} = \frac{1}{0.082} = 12.2$$

In this example, the thermal bridging due to the shelf angle is responsible for 38% (1.88/4.94) of the heat loss while the shelf angle itself (6' x 6') represents only 5% of the area of the wall assembly.

A WORD ABOUT CONDENSATION

In addition to creating a breach in heat flow, thermal bridges reduce the surface temperature on internal surfaces as they penetrate the thermal envelope. This can result in potential moisture problems. Moisture within the building structure can corrode metal and deteriorate concrete over time.

In cold climates, moisture can collect on the internal surfaces of exterior walls. When these surfaces become too cold due to a thermal bridge, the relative humidity of the air in the area of the thermal bridge could exceed 65%. The higher the relative humidity, the greater the water vapor content. Condensation will occur on cold surface areas when the temperature at the internal surface of an external wall is at or below the dew point temperature of the air.

Using a temperature factor (T_f) is the best way to assess condensation risk. The T_f can be used to predict whether condensation will occur by comparing the coldest interior surface temperature to the dew point temperature. Condensation will occur if the interior surface temperature is less than the dew point temperature.

$$T_f = (T_{is} - T_e) / (T_i - T_e)$$

Where T_{is} is the coldest internal surface temperature, T_i is the internal temperature and T_e is the external air temperature. Critical temperature factors depend on building use and the expected relative humidity in the thermal envelope.

More thermally efficient building envelope details using thermal break materials and vapor barriers will reduce the risk of condensation by forcing the dew point outwards of the thermal envelope. Thermally broken structural connections prevent excessive heat flow and potential condensation problems associated with thermal bridging.

STRATEGIES TO PREVENT THERMAL BRIDGING

Thermal transmittances due to thermal bridging can be reduced or prevented by using materials with low thermal conductivities or creating a thermal break in the interface detail connection. This is accomplished by introducing a material or component which has a much lower thermal conductivity in the connection where it penetrates the thermal envelope.

Materials with low thermal conductivities can be manufactured/engineered from a wide array of plastic composites and elastomeric or foam based compounds. In thermally broken, structural connections such as cladding attachments, canopies and balconies, materials used as thermal breaks must have high strength, stiffness and creep resistance.

High strength materials however tend to have high thermal conductivity values whereas low strength materials tend to have low thermal conductivity values. The most effective thermal break solutions will therefore have sufficient strength for structural support and a low thermal conductivity capable of reducing heat flow and preventing a thermal bridge.

Thermoplastics (nylon, PVC, Teflon) and rubber materials (neoprene, nitrile) can have low thermal conductivities, however they deflect, creep and take a permanent set under load. Long-term plastic deformation may not be desirable in a structural connection.

Thermoset materials on the other hand, such as polyurethanes and epoxy resins are ideal for use as thermal breaks because they are much more resistant to creep and deformation under load while also having low thermal conductivities.



THERMAL BRIDGING

REDUCING THERMAL TRANSMITTANCE

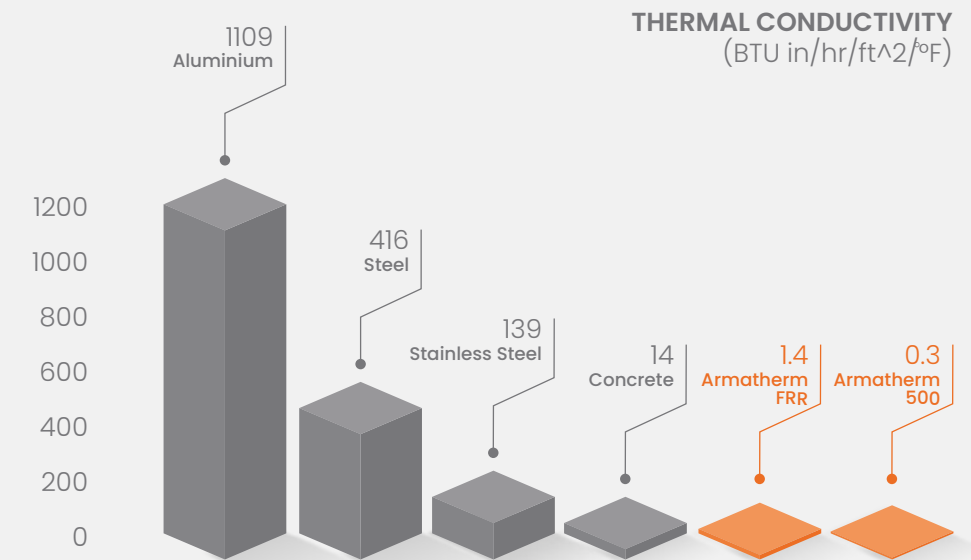

Thermal conductivity values of Armatherm structural thermal break materials as compared to standard building materials.

It has been stated that thermal bridges in conventional construction may reduce insulation effectiveness by as much as 50%, resulting in wall assemblies and interface details that do not meet current energy code requirements for minimum U value.

Examples of typical assemblies, transitions and structural connections where Armatherm™ thermal break materials can be used to reduce thermal transmittance and improve U values follow.

OUR PRODUCTS

ARMATHERM™ FRR

Armatherm™ FRR structural thermal break material provides a combination of low thermal conductivity and high compressive strength and has been used in hundreds of structural steel framing connections transferring load in moment and shear conditions. Armatherm™ FRR can support up to 40,000 psi and has an R value of 0.9 per inch. The material is made of a reinforced, thermoset resin which is fire resistant and has very limited creep under load, making it the ideal material for use in structural and façade thermal break connections.

Applications using Armatherm™ FRR to reduce heat flow include:

- ✔ Balcony / canopy
- ✔ Equipment screen / wind screen
- ✔ Roof davits and anchors
- ✔ Mullion connections
- ✔ Shelf angles
- ✔ Steel framing connections



ARMATHERM™ 500

Armatherm™ 500 is a high strength, thermoset polyurethane manufactured in several densities which can support loads up to 2,150 psi with R values as high as 3.8 per inch which is superior to the properties of aerated concrete and wood blocking.

Applications using Armatherm™ 500 to reduce heat flow include:

- ✔ Balcony / canopy
- ✔ Equipment screen / wind screen
- ✔ Roof davits and anchors
- ✔ Mullion connections
- ✔ Shelf angles
- ✔ Steel framing connections

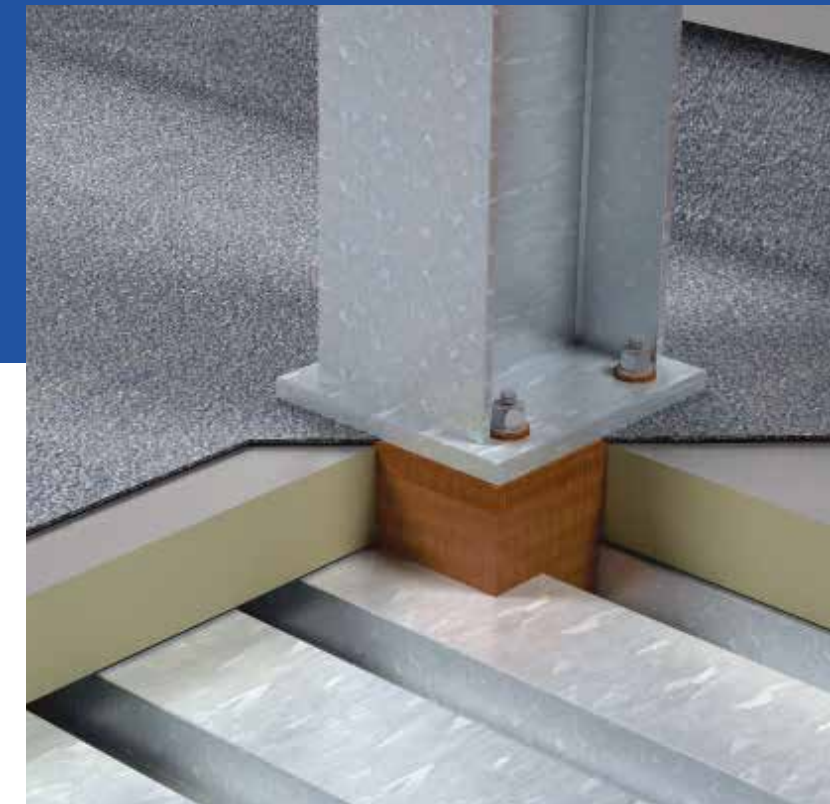

MASONRY SHELF ANGLE

Masonry veneer walls require tie-backs and shelf angles which form significant thermal bridges and can reduce a walls' R value by as much as 50% making it difficult to meet energy codes. Shelf angles transfer the masonry load back to the buildings' structural steel or concrete slab edge interrupting the continuous insulating layer of the wall assembly creating a continuous thermal bridge.

To improve the U value of a masonry wall assembly, the shelf angle can be connected to the structure at discreet, evenly spaced points such as plate "blades" allowing the insulation to pass behind the steel angle, reducing the effects of a continuous thermal bridge. However, building the shelf angle outwards requires larger geometries and additional material to support the cantilevered load.

Alternatively, Armatherm™ FRR material can be used directly behind the shelf angle as a thermal break within the insulating layer significantly reducing the linear transmittance of the shelf angle. Rigid, metal flashing used as waterproofing can then be replaced with a non-conductive, self-adhered membrane.

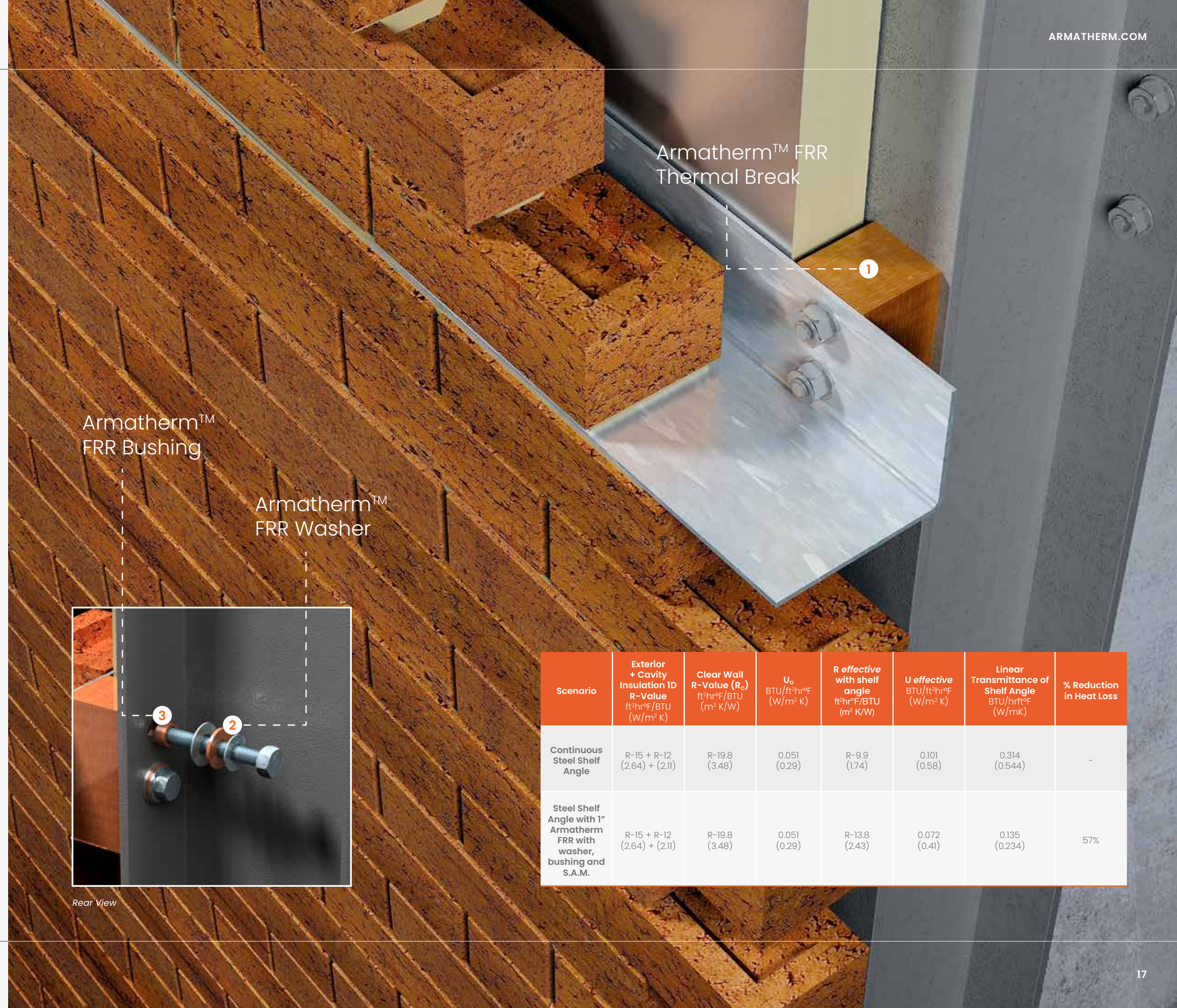

Armatherm™ FRR Thermal Break

1

Armatherm™ FRR Bushing

Armatherm™ FRR Washer

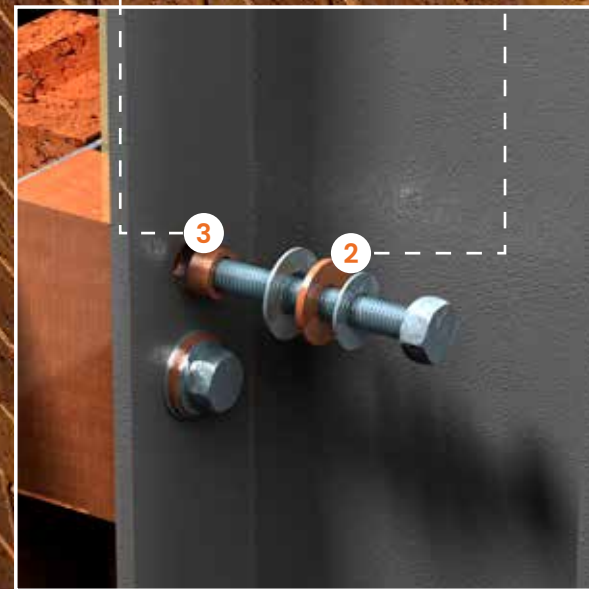

Rear View

Scenario	Exterior + Cavity Insulation 1D R-Value ft ² hr ² F/BTU (W/m ² K)	Clear Wall R-Value (R _o) ft ² hr ² F/BTU (m ² K/W)	U _o BTU/ft ² hr ² F (W/m ² K)	R effective with shelf angle ft ² hr ² F/BTU (m ² K/W)	U effective BTU/ft ² hr ² F (W/m ² K)	Linear Transmittance of Shelf Angle BTU/hrft ² F (W/mK)	% Reduction in Heat Loss
Continuous Steel Shelf Angle	R-15 + R-12 (2.64) + (2.11)	R-19.8 (3.48)	0.051 (0.29)	R-9.9 (1.74)	0.101 (0.58)	0.314 (0.544)	-
Steel Shelf Angle with 1" Armatherm FRR with washer, bushing and S.A.M.	R-15 + R-12 (2.64) + (2.11)	R-19.8 (3.48)	0.051 (0.29)	R-13.8 (2.43)	0.072 (0.41)	0.135 (0.234)	57%

STEEL CANOPY BALCONY

The most common interface details for structural framing are canopies and balconies that use cantilevered steel or aluminum elements. These elements are typically connected to slab edges or spandrel beams on the interior side of the thermal envelope passing through insulation and air barrier layers. The R value of a wall assembly can be reduced by as much as 60%.

Using a thermal break at these connections will improve the U value of a wall assembly which includes this type of point transmittance. Armatherm™ FRR structural thermal break material is capable of transferring the loading in moment and shear connections without creating significant rotation. In fact, in structural testing, Armatherm™ FRR has been evaluated in moment and shear connections for creep, rotation and any impact on bolt force. While minimizing heat flow, the structural performance of these connections must remain acceptable.

Armatherm™ FRR Thermal Break

1

Armatherm™ FRR Bushing

Armatherm™ FRR Washer

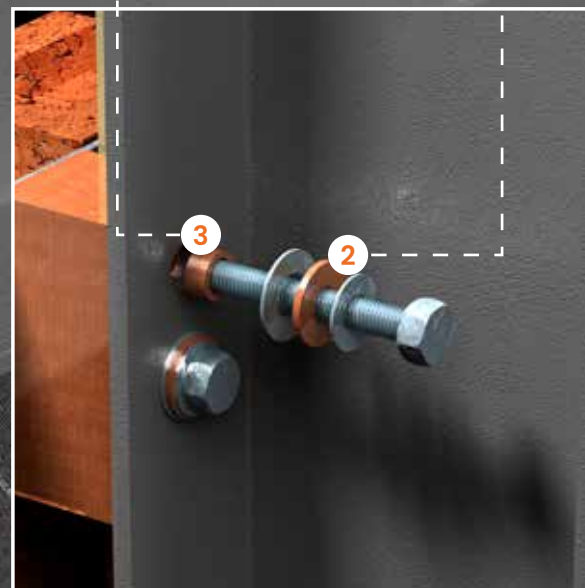

Rear View

Scenario	Exterior Insulation ID R-Value ft ² hr ² F/BTU (m ² K/W)	Clear Wall R-Value (R _o) ft ² hr ² F/BTU (m ² K/W)	U _o BTU/ft ² hr ² F (W/m ² K)	R effective with Beam ft ² hr ² F/BTU (m ² K/W)	U effective with Beam BTU/ft ² hr ² F (W/m ² K)	Point Transmittance of Beam BTU/hr ² F (W/K)	% Reduction in Heat Loss
Continuous Beam	R-15 (2.64)	R-18.5 (3.25)	0.054 (0.31)	R-6.9 (1.21)	0.145 (0.83)	1.73 (0.92)	-
1" Armatherm FRR using steel bolts	R-15 (2.64)	R-18.5 (3.25)	0.054 (0.31)	R-7.3 (1.28)	0.138 (0.78)	1.56 (0.83)	10%
1" Armatherm FRR using stainless steel bolts	R-15 (2.64)	R-18.5 (3.25)	0.054 (0.31)	R-8.4 (1.48)	0.119 (0.68)	1.16 (0.62)	33%
1" Armatherm FRR using stainless steel bolts and FRR washers and bushings	R-15 (2.64)	R-18.5 (3.25)	0.054 (0.31)	R-9.2 (1.61)	0.109 (0.62)	0.95 (0.50)	45%
2" Armatherm FRR using stainless steel bolts and FRR washers and bushings	R-15 (2.64)	R-18.5 (3.25)	0.054 (0.31)	R-10.2 (1.79)	0.098 (0.56)	0.72 (0.38)	58%

FOUNDATION TO WALL TRANSITION

Foundations are part of a buildings' thermal envelope. The intersection at a slab on grade to foundation wall and the exterior wall to foundation transition are both areas where heat flows out of a building due primarily to non-continuous insulation details.

The linear transmittance at these locations can be reduced by as much as 60% by using an efficient, structural thermal break. Armatherm™ 500 is a load bearing, thermal break material manufactured in several densities to provide a range of load capacities with R values as low as R 3.8 per inch.

Note Foundation insulation length under floor slab was 12" for these scenarios. The linear transmittance can be reduced further by increasing the length of the slab insulation. L values are similar to F factors and are the heat flow of the slab on grade per unit length of the slab perimeter.

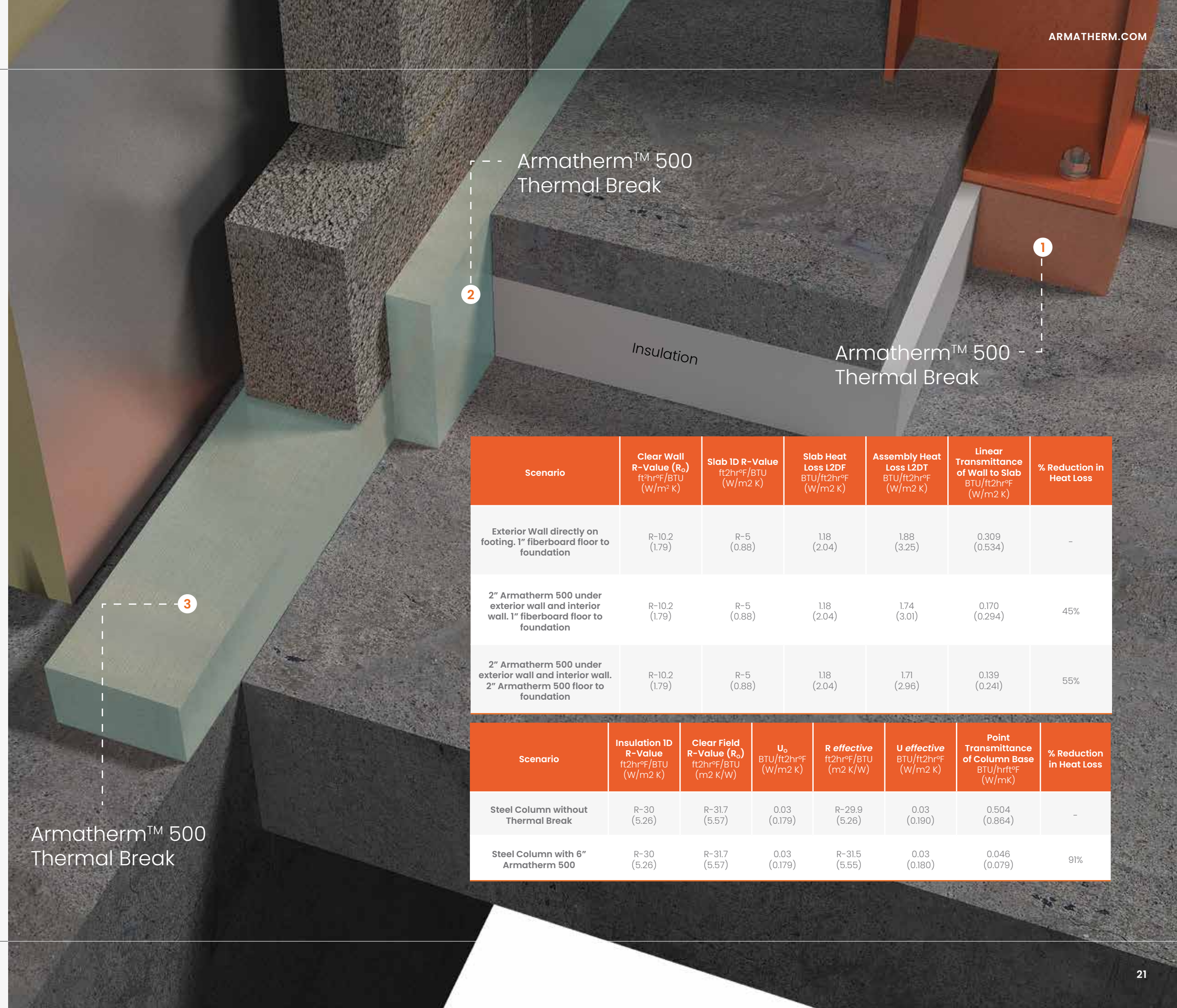

Armatherm™ 500 Thermal Break

Insulation

Armatherm™ 500 Thermal Break

Armatherm™ 500 Thermal Break

Scenario	Clear Wall R-Value (R _o) ft ² hr ² F/BTU (W/m ² K)	Slab 1D R-Value ft ² hr ² F/BTU (W/m ² K)	Slab Heat Loss L2DF BTU/ft ² hr ² F (W/m ² K)	Assembly Heat Loss L2DT BTU/ft ² hr ² F (W/m ² K)	Linear Transmittance of Wall to Slab BTU/ft ² hr ² F (W/m ² K)	% Reduction in Heat Loss
Exterior Wall directly on footing. 1" fiberboard floor to foundation	R-10.2 (1.79)	R-5 (0.88)	1.18 (2.04)	1.88 (3.25)	0.309 (0.534)	-
2" Armatherm 500 under exterior wall and interior wall. 1" fiberboard floor to foundation	R-10.2 (1.79)	R-5 (0.88)	1.18 (2.04)	1.74 (3.01)	0.170 (0.294)	45%
2" Armatherm 500 under exterior wall and interior wall. 2" Armatherm 500 floor to foundation	R-10.2 (1.79)	R-5 (0.88)	1.18 (2.04)	1.71 (2.96)	0.139 (0.241)	55%

Scenario	Insulation 1D R-Value ft ² hr ² F/BTU (W/m ² K)	Clear Field R-Value (R _o) ft ² hr ² F/BTU (m ² K/W)	U _o BTU/ft ² hr ² F (W/m ² K)	R effective ft ² hr ² F/BTU (m ² K/W)	U effective BTU/ft ² hr ² F (W/m ² K)	Point Transmittance of Column Base BTU/hrft ² F (W/mK)	% Reduction in Heat Loss
Steel Column without Thermal Break	R-30 (5.26)	R-31.7 (5.57)	0.03 (0.179)	R-29.9 (5.26)	0.03 (0.190)	0.504 (0.864)	-
Steel Column with 6" Armatherm 500	R-30 (5.26)	R-31.7 (5.57)	0.03 (0.179)	R-31.5 (5.55)	0.03 (0.180)	0.046 (0.079)	91%

ROOF PENETRATION

The roof is part of the building envelope where penetrations such as davits, anchors and supports for dunnage extend through the thermal envelope and roof insulation creating non-continuous insulation. These interface details are typically connected to interior trusses or structural elements creating a thermal bridge and point transmittance. The R value of the roof can be reduced by up to 40% in these areas.

A thermal break at these locations will improve the U value of the roof assembly and prevent potential condensation problems at the structural connection. Armatherm FRR and 500 series thermal break materials can transfer the loading conditions at these locations while significantly reducing heat flow. The transmittance can be improved by as much as 80%.

Material data information for the thermal modelling examples shown is available upon request. Please contact us to obtain these or the thermal performance and condensation indices results of other modeled areas in the building envelope from our thermal modeling library.

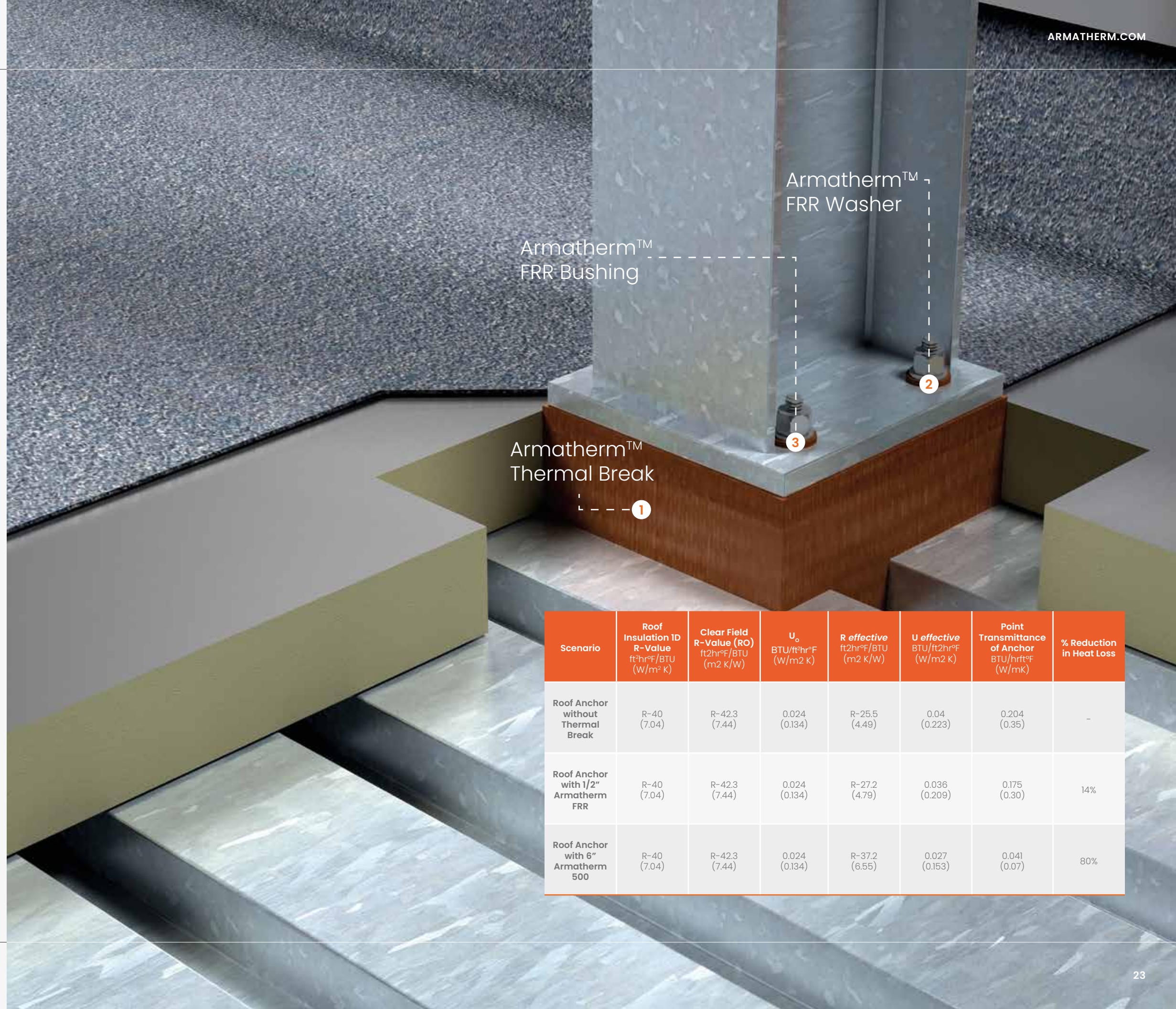

Armatherm™
FRR Bushing

Armatherm™
FRR Washer

Armatherm™
Thermal Break

Scenario	Roof Insulation ID R-Value ft ² hr ² F/BTU (W/m ² K)	Clear Field R-Value (R0) ft ² hr ² F/BTU (m ² K/W)	U ₀ BTU/ft ² hr ² F (W/m ² K)	R effective ft ² hr ² F/BTU (m ² K/W)	U effective BTU/ft ² hr ² F (W/m ² K)	Point Transmittance of Anchor BTU/hrft ² F (W/mK)	% Reduction in Heat Loss
Roof Anchor without Thermal Break	R-40 (7.04)	R-42.3 (7.44)	0.024 (0.134)	R-25.5 (4.49)	0.04 (0.223)	0.204 (0.35)	-
Roof Anchor with 1/2" Armatherm FRR	R-40 (7.04)	R-42.3 (7.44)	0.024 (0.134)	R-27.2 (4.79)	0.036 (0.209)	0.175 (0.30)	14%
Roof Anchor with 6" Armatherm 500	R-40 (7.04)	R-42.3 (7.44)	0.024 (0.134)	R-37.2 (6.55)	0.027 (0.153)	0.041 (0.07)	80%

ADDITIONAL ENVELOPE LOCATIONS TO CONSIDER



FENESTRATION

Windows and doors can severely degrade a whole wall thermal performance. Window R values have the largest impact on a walls' overall R value. Transition and framing details can have a major impact because these connections create conductive heat losses (thermal bridges) that pass through the thermal envelope. Armatherm™ 500 series thermal break material has an R value as low as 3.8 per inch and can be used between framing connections and profiled/machined for use as window sill components.



PARAPET/ROOF EDGE

Roof to wall intersections and parapet locations require structural framing for support, which prevents continuous insulation from roof to wall. The designs of these intersections often create thermal bridges. Armatherm™ structural thermal break materials can be used at these locations to create continuous insulation and improve heat loss at these interface details by as much as 30%.



CURTAIN WALL MULLION CONNECTIONS

Like shelf angles, curtain wall mullions have an impact on the thermal performance of a building's envelope. Small in area, but required in many locations, the total heat loss due to these highly conductive elements can be substantial. Armatherm™ FRR thermal break material transfers the structural loads of curtain wall frames and spandrel panel connections while reducing heat loss.



CAST IN SITU CONCRETE BALCONY

Uninsulated concrete balconies are a classic example of a highly conductive, structural thermal bridge. The steel reinforcing bars that transfer shear and moment load in a cantilevered concrete slab, greatly increase heat flow resulting in poor linear transmittance values at the connection point to the main floor slab. Conditioning the floor area on the internal side of these connections in cold climates is an enormous waste of energy. To reduce heat loss and prevent the thermal bridge created by steel reinforced concrete, Armatherm™ 500 material and GRP reinforcing bars can be used at this structural connection. Heat loss can be improved by 50% using this approach.



CLADDING/FAÇADE CONNECTIONS

Continuous exterior insulation is almost always compromised by metallic structural connections such as clips and girts which create a thermal bridge when connected to steel stud framing. These connections in conjunction with the steel studs have a significant impact on the U value of wall assemblies. Insulation effectiveness can be reduced by as much as 50% due to these heat flow paths. ArmaGirt™ Z-Girt improve the U value of cladding and wall panel assemblies by eliminating the use of highly conductive metal girts and aluminum brackets creating wall assemblies that are up to 98% efficient.



CLADDING/FAÇADE CONNECTIONS

Steel columns traditionally extend through the building envelope (floor slab) and insulation at their base. In low temperature buildings such as freezer rooms and cold storage facilities, this creates a thermal bridge and point transmittance between the steel column and the foundation. This is also the case for columns which bear on exposed foundation walls. Armatherm™ 500, high strength material can support and transfer column loads while providing an effective thermal break between the column base and concrete foundation. With R values as low as R 3.8 per inch, Armatherm™ can help to meet the baseline insulation requirements for floors in refrigerated storage facilities more efficiently than timber or aerated concrete.

TERMS

Thermal Envelope is a term used to include all building elements that totally encase the heated or cooled spaces of a building to resist heat flow between the interior and exterior.

U value (U) is the heat flow through an assembly per unit area per temperature difference. The amount of heat an assembly is capable of transmitting through it. U value accounts for all conductance of every element in the assembly.

Clear field transmittance (U_o) is the heat flow through a wall, roof or floor assembly, which includes the effects of uniformly distributed thermal bridging components such as; brick ties, cladding attachments or framing studs.

Linear transmittance (psi) is the additional heat flow caused by details that can be defined by a characteristic length. This includes slab edges, parapets, corners, shelf angles and transitions between assemblies. The linear transmittance is a heat flow per unit length.

Point transmittance (X_{chi}) is the additional heat flow caused by thermal bridges that only occur at a single location. This includes canopy, balcony, wind screen, davits and intersections between linear details. The point transmittance is a single additive amount of heat loss.

ARMATHERM

USA OFFICE

Armatherm
1 Titleist Drive,
Acushnet,
Massachusetts
02743

T 844-360-1036

E sales@armatherm.com

ARMATHERM.COM